



# 3010S2D Integrated Amplifier

## Quick Start

Thank you for purchasing the Exposure 3010S2D Integrated Amplifier.

### Before you start

Please check the contents in the box:



Exposure 3010S2D Integrated Amplifier



HS-102 Exposure System remote control



Mains cable



Ensure your unit is switched off and that the volume control knob is at its minimum.



Please note that your Exposure 3010S2D Integrated Amplifier may take up to 48 hours to "run-in" before reaching its optimal performance. Each subsequent "run-in" will then take about 20 minutes.



The Exposure 3010S2D Integrated Amplifier is equipped with a heat sensor which will automatically switch off the power amplifier section when an abnormally high temperature is reached. To reset the output, switch off the amplifier and allow to cool for 10 to 15 minutes.

## 1 Installation

The Exposure 3010S2D Integrated Amplifier : Front View



a) Set the volume control to minimum before connecting or disconnecting any cable.



b) Connect the mains cable to the IEC mains input socket.



c) Connect to the mains outlet on the wall. DO NOT switch on until all input and output connections are made.

## 2 Source Component Connections

The Exposure 3010S2D Integrated Amplifier : Back View



The Exposure 3010S2D Integrated Amplifier is fitted with six (6) line level RCA Phono inputs, suitable for connection to CD players, tuners and tape or disc recorders.

AV - This input has a fixed gain for connection to AV Receivers. When the AV is selected the volume control has no effect and the volume LED will be extinguished.

### Inputs

- Connect RCA Phono cables from each source component (CD Player/Tuner/Tape/Disc Recorder/Turntable/Video Player) to the respective input.
- Ensure left and right channels are connected correctly. (Right channel is marked in red)
- The tape input is labeled TAPE PLAY.

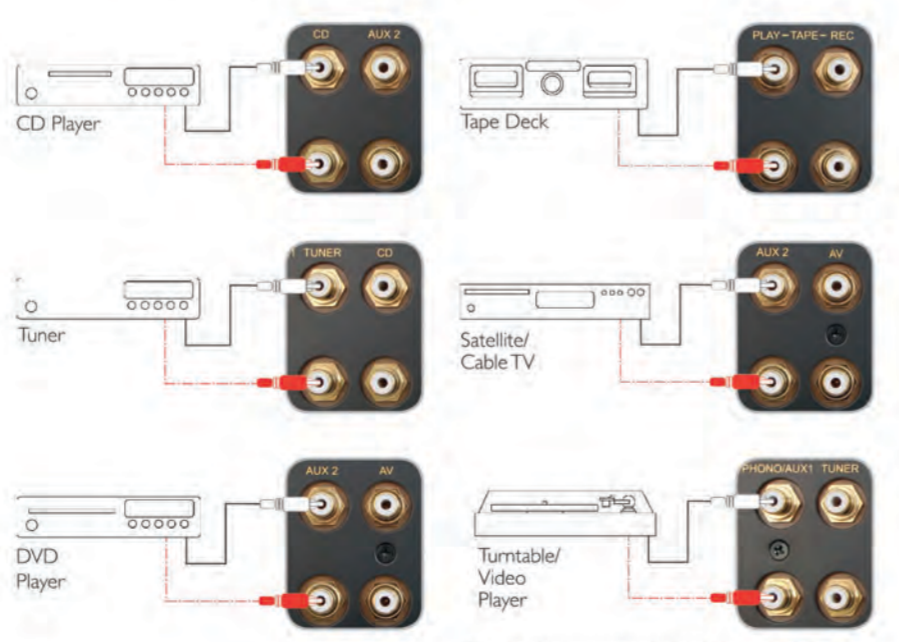

\* Turntable connection requires the installation of an optional MM or MC Phono Card.

### Outputs

- TAPE REC** Provides line level output signals for recording.
- PRE-OUT** Provides left and right channel output signals appropriate for connection to an Exposure 3010S2 Power Amplifier (a future-proof upgrade).

## 3 Loudspeaker Connections

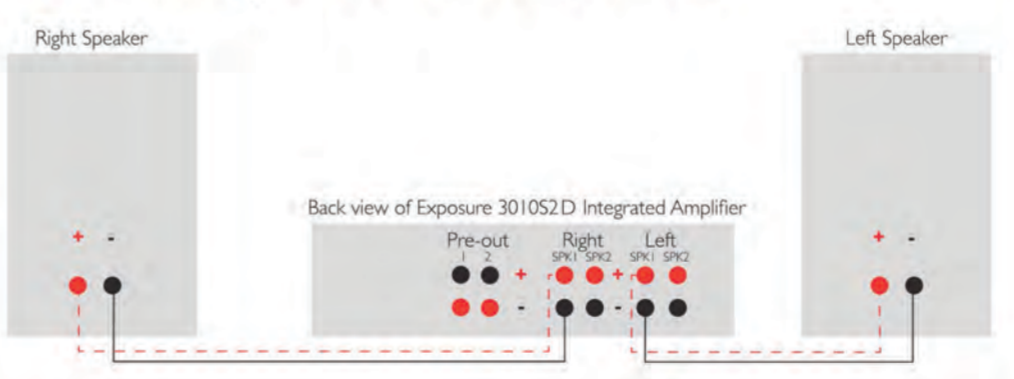

- Connect left and right loudspeakers to corresponding left and right speaker outputs on amplifier.
- Connect (+) terminal of loudspeaker to (+) terminal of the amplifier.
- Connect (-) terminal of loudspeaker to (-) terminal of the amplifier.

### Bi-wired Connection

Bi-wiring may provide a useful gain in subjective performance. Should you choose this option, please refer to the "Extended Set-Up" instructions overleaf.

### Bi-amping of Loudspeakers

Bi-amping of loudspeakers using a 3010S2D Integrated and a 3010S2 Power Amplifier provides a useful gain in subjective performance. For this operation, please refer to the "Extended Set-Up" instructions overleaf.

## 4 Operation



a) Turn amplifier volume control to minimum.



b) Press power switch. The LED power indicator will light up. The amplifier output relay will activate after a 6-second delay.



c) Without playing any CD Player/Tuner/Tape/Disc Recorder/Turntable/Video Player; turn the volume control knob slowly clockwise to around 30%. You should only hear a faint hiss.



d) Turn the source selection knob to select a live source component (CD Player/Tuner/Tape/Disc Recorder/Turntable/Video Player).

e) Audio should now be heard when the source component is played.

## 5 Remote Control

The source selection knobs will rotate to match selections made on remote control.



Select the functions of the Exposure CD player (if any).

Mutes the volume output to minimum. Indicator lights on VOLUME and INPUT SELECTOR knobs will be turned off. Press again or press the VOL + button to return volume to its previous level and restore indicator lights.

Increase/decrease the volume. Indicator light on VOLUME knob will flash as volume is adjusted.

Select input sources. Indicator light on the INPUT SELECTOR knob will flash as sources are selected.

### Installation of a MC or MM Phono Module or a DAC Module.

For details, please refer to the "Extended Set-Up" section overleaf or contact your dealer.

## Exposure 3010S2D Integrated Amplifier : Extended Set-Up

Although the Exposure 3010S2D Integrated Amplifier is able to drive almost any loudspeaker system, the best results will most likely be achieved with speakers rated at 8ohms. While the Exposure 3010S2D Integrated Amplifier is compatible with most types of loudspeaker cables, the type of cables used can influence the subjective performance of your system.

Please ask your Exposure dealer for advice on bi-amping, loudspeaker cable compatibility and how to get the best from your Exposure 3010S2D Integrated Amplifier

Note : The Exposure 3010S2D Integrated Amplifier is internally protected against damage from short circuits. However, no such protection is infallible, and damage may occur if positive and negative speaker cables are inadvertently connected together.

### Bi-wiring

The Exposure 3010S2D Integrated Amplifier is fitted with two sets of 4mm loudspeaker sockets for bi-wired connections. Another pair of speaker wires is required for this operation.

1. Ensure that the links at the speaker terminals between the high frequency and the low frequency are removed on both loudspeakers.
2. Follow the diagram on the right for connecting a pair of loudspeakers in bi-wiring mode.

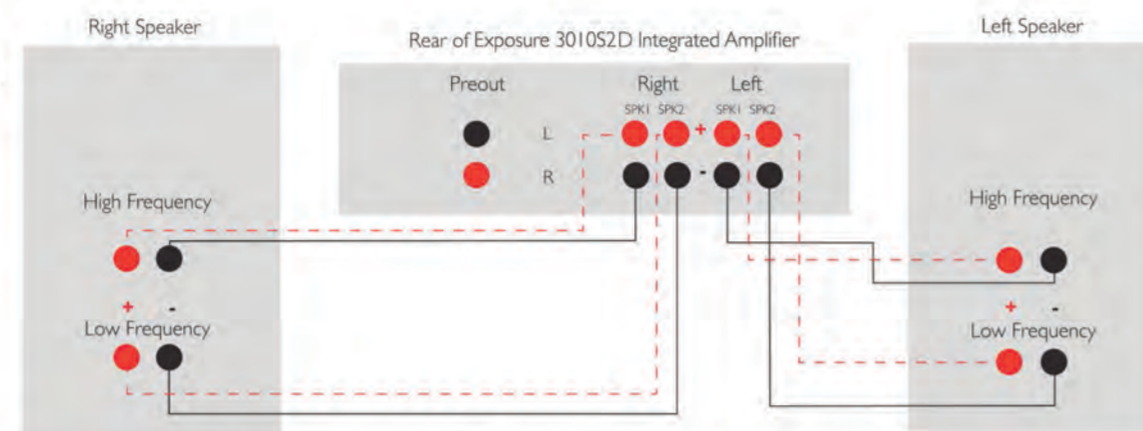

Connecting a pair of loudspeakers in bi-wiring mode

### Bi-amping of Loudspeakers

Bi-amping of suitable loudspeakers using a 3010S2D Integrated Amplifier and a 3010S2 Power Amplifier provides a useful gain in subjective performance. The Integrated Amplifier is used to drive the treble units and the Power Amplifier is used to drive the bass units through the loudspeaker's split crossover with the joining links removed.

1. Check your loudspeaker user manual for the wiring connections.
2. Follow the diagram on the right for connecting a pair of loudspeakers in bi-amping mode.

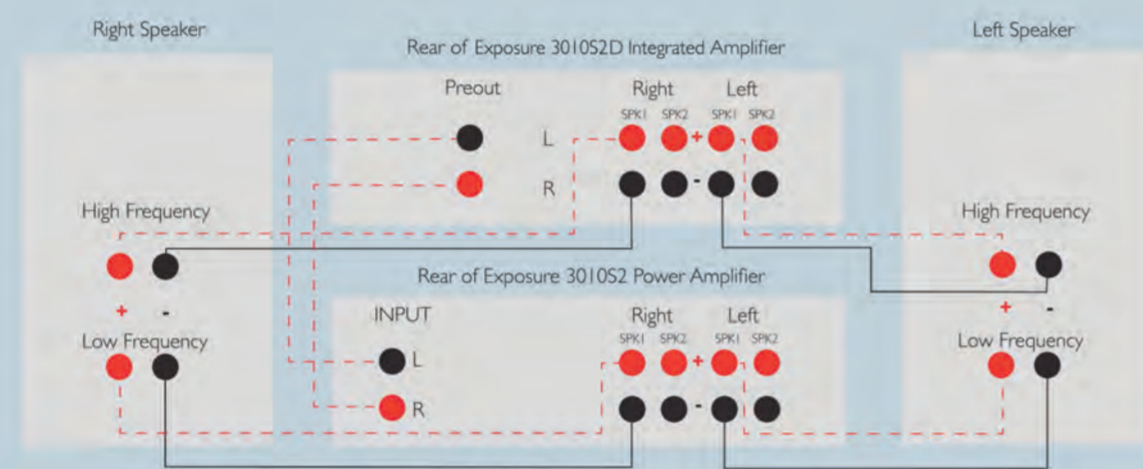

Connecting a pair of loudspeakers in bi-amping mode

### Installation of a MC or MM Phono Module or a DAC Module

This is best carried out by your dealer. However, if you wish to attempt installation yourself:



1. Switch off the unit.



2. Remove the mains cable from the wall and the IEC socket.



3. Remove the four cover screws.



4. Slide the cover back about 2cm until it is free to move upwards to reveal the main circuit board.



5. Remove the small jumper board that is fitted on the right hand side at the back.

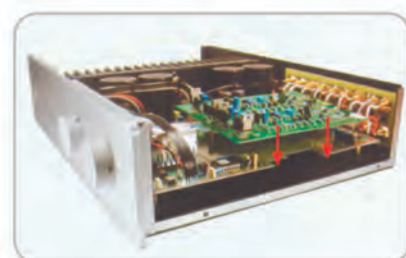

6. Observe the position of the plug on the phono card and carefully plug it in, ensuring that all of the pins are inserted correctly into their connectors.

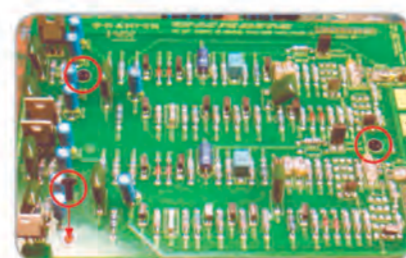

7. Fit the three M3 bolts that are supplied with the phono card. Fit the three M3 bolts provided with the DAC card as well as the large nut & washer to the BNC socket on the outside of the unit.



8. Replace the cover and screws.

## Safety

Incorrect installation or inappropriate use of the Exposure 3010S2D Integrated Amplifier may result in injury due to electrical shock.

- Ensure that the voltage rating on the rear panel of this unit matches that of your local mains supply.\*
  - Ensure that the mains cable and plug supplied with this unit are also correct. (Contact your dealer immediately if this is not the case).
  - This unit is protected by a mains fuse, which is accessible as part of the IEC socket on the rear panel.
  - Fuse replacement specifications:  
220/240V units T4A fuse  
110/120V units T8A fuse
  - Protect the unit against all forms of liquid. Never expose unit to dripping or splashing, or place objects filled with water, such as vases, on the unit.
  - Unplug unit from mains when not in use for prolonged periods.
  - Do not open this unit - there are NO user serviceable parts inside (except to install or change a phono card).
  - Set the volume control to minimum before turning this unit on or off.
  - Ensure that this unit is switched off when connecting or disconnecting speaker and interconnect cables.
- \* Contact your Exposure dealer or distributor for advice on moving your equipment to another country or territory.

## Caution

For a long and trouble-free life of your Exposure 3010S2D Integrated Amplifier, please ensure the following:

- Do not short circuit the speaker terminals.
- Do not remove the cover of the Integrated Amplifier or dismantle the case (except to install or change phono card).
- Protect unit against all forms of liquid. Never expose unit to dripping or splashing, or place objects filled with water, such as vases, on the unit.
- Do not operate the Integrated Amplifier in damp environments or allow liquids to enter the unit.
- Do not attempt to bypass the mains fuse or replace the fuse with one of a different specification.
- Do not place the Integrated Amplifier in a position which restricts cooling airflow around its case.
- Do not use abrasive or solvent-based cleaning fluids on the Integrated Amplifier's case.

Failure to observe these precautionary measures may void your warranty.

## Product disposal instructions

The symbol shown here and on the product means that the product is classed as electrical or electronic waste and should not be disposed of with other household waste at the end of its working life.



The Waste of Electrical and Electronic Equipment (WEEE) Directive (2002/96/EC) has been put in place to recycle products using the best available recovery and recycling techniques to minimize the impact on the environment, treat any hazardous substances and avoid increasing landfill.

When you have no further use for this product, please remove any batteries and dispose of them and the product as per your local authority's recycling process. For more information please contact your local authority or the retailer where the product was purchased.

## Technical Specifications

Power Output:	110 Watts per channel at 1KHz into 8 Ohms
Input Impedance:	17K Ohms minimum (line input)
Input Sensitivity:	250mV
Pre-amplifier Output:	1V for rated input (gain + 18dB full volume)
Frequency Response:	20Hz – 20Khz ± 0.5dB
Total Harmonic Distortion:	<0.03% at rated output, ref 1 KHz
Signal to Noise Ratio:	>100dB ref rated output
Channel Separation:	>60dB, 20Hz - 20KHz,
Mains Supply:	110/120V or 220/240V, 50/60Hz (factory set)
Power Consumption:	<400VA, 8 Ohms load both channels driven
Dimensions (H x W x D):	115 mm x 440 mm x 300 mm
Nett Weight (Unpacked):	12 kg
Gross Weight (Packed):	14 kg

## Exposure Warranty Policy

1. The Exposure warranty entitles you to FREE repair of this unit for the first three (3) years from the date of purchase.
2. This warranty is valid only if the unit is purchased from an authorised Exposure dealer; registered with the authorised agent in your country of residence and (the following is optional but recommended) registered at [www.exposurehifi.com/warranty.html](http://www.exposurehifi.com/warranty.html).
3. The agent accepts no responsibility for defects arising from accident, misuse, abuse, wear and tear, neglect or through unauthorised adjustment and or repair or replacement of any components, nor will they accept responsibility for damage or loss occurring during transit to or from the person making a claim under warranty.
4. The Exposure warranty covers:
  - **Parts and labour costs for three (3) years from the date of purchase.** Please retain your original receipt as proof of purchase and purchase date. The guarantee is extended only to the original purchaser and is not transferable.

### When making claims under this warranty:

1. The unit should be suitably packed and returned to the dealer from whom it was purchased, or directly to the local distributor, together with proof of purchase or a copy of the dated sales receipt.
2. If necessary the unit should be sent carriage pre-paid by a reputable carrier, NOT by post.
3. No responsibility is accepted for the unit whilst on transit to the dealer or agent, and customers are advised to insure the unit against loss or damage whilst in transit.
4. Any tampering or alteration made to the serial number on the unit will invalidate the warranty.
5. The dealer or the agent shall notify the customer when the repairs have been completed. The customer must claim the goods within fourteen (14) days from the date of notice, failing which, the Company reserves the right to impose storage charges.
6. The Company reserves the right to dispose of the unit after 90 days from the date of notice in a manner that it sees fit and without compensation to the customer.