

GUIDELINES

PLEASE TAKE NOTE OF THE FOLLOWING GUIDELINES

Please read these instructions thoroughly before you begin the assembly and installation.

Frame and board can be adjusted in height separately and offer you a lot of flexibility and precision. Take yourself some time to go through this initial installation process.

The metal parts and the support are heavy and can be scratched easily if not handled with the required caution. Additionally pay attention to the high risk of injury for your feet caused by falling parts! Protect yourself with the appropriate footwear (hard-toed safety shoes).

Make sure that the overall weight resulting from the weight of the STOIC metal frame, the weight of the support plate and your electronic device does not exceed the load bearing capacity of your piece of furniture.

The STOIC Basis made from stainless steel was cleaned before shipment to you. For this reason, the stainless steel frame is only to be touched with gloves. Polished stainless steel is tarnishing over time. If necessary, clean the frame with a stainless steel cleaner.

A frame made of powder coated steel is best cleaned with a damp cloth and a little detergent.

ASSEMBLY

ASSEMBLY OF THE STOIC BASIS

Place the metal frame on a soft support to protect the table top and the frame from scratching.

Start with placing the feet to the basis. The 8 mm machine screw thread fits to the screw socket fixed on the triangle console. Fix the **spike feet** with the **M8** nuts from top. The thread of the spike feet shall poke out of the nuts not more than approximately 5 mm. Do not fully tighten the spike feet yet.

Stick the self-adhesive **felt lamination sheet** underneath the spike support disk.

Place the frame with its four spike feet carefully onto the spike disks.

Use the spirit level to **adjust** the frame. Spin the spike threads by use of the 4 mm Allen key and finally tighten them with the 13 mm wrench.

Insert the four 6 mm **steel spikes** with the tip up into the frame and fix them only slightly with the **M6** nuts from below.

Carefully place the **support plate** on the spikes. Before placing a stone plate, protect the metal by placing soft cloths over the frame.

Make sure that the 6 mm spikes slide into the spike receptacles on the underside of the support plate. If necessary, the spike positions must be corrected by loosening and shifting.

Use the spirit level to **adjust** the support plate. To adjust the 6mm spikes, remove the support plate.

Finally, fix the 6mm spikes in the final position by tightening the nut with the 10 mm wrench.

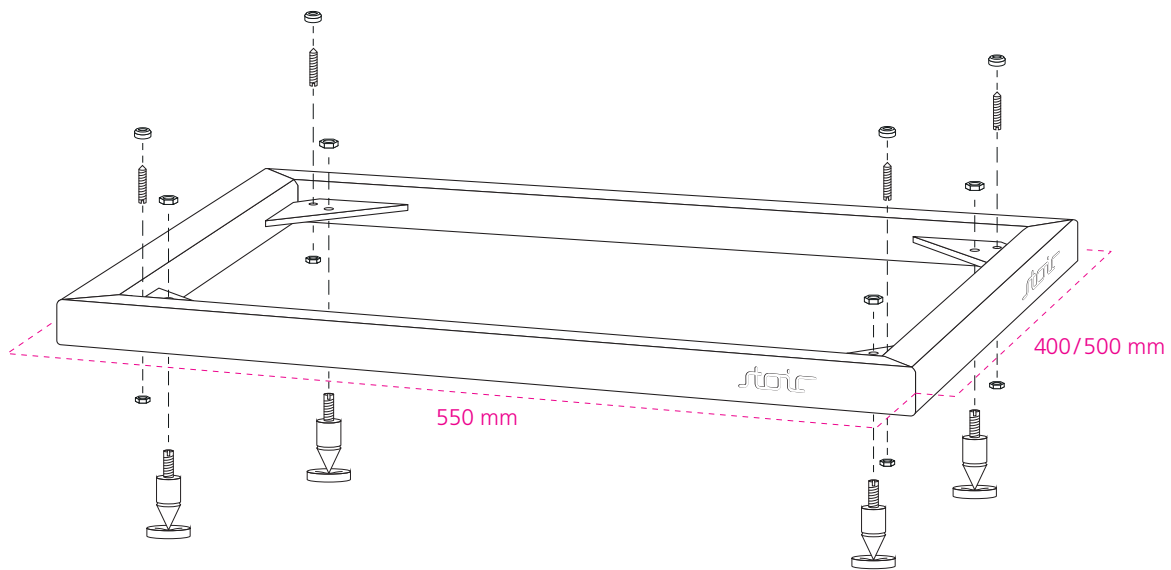

TOOLS

TOOLS NEEDED

- › 10 mm wrench
- › 13 mm wrench

LIEFERUMFANG

- › metal frame, sand filled
- › support plate with spike receptacles
- › 4 stainless steel spikes M6
- › 4 stainless steel lock nuts M6 with washers
- › 4 stainless steel screw nuts M6 for spikes
- › 4 stainless steel spike feet M8
- › 4 stainless steel lock nuts M8
- › 4 stainless steel spike disks
- › 4 self-adhesive felt lamination sheets for spike disks
- › precision spirit level
- › Allen 3 mm angle key
- › Allen 4 mm angle key
- › work gloves
- › small can with polish (for stainless steel version)

TECHNICAL SPECIFICATIONS

TECHNICAL SPECIFICATIONS OF STANDARD MODELS

- › **Outer mass = stand area:**
400 mm x 550 mm / 500 mm x 550 mm
- › **Weight** (depending on size):
metal frame including sand filling: approx. 7 kg / 8 kg
wooden plate: approx. 4.5 kg / 5.5 kg
optional wooden plate with sand filling:
approx. 6 kg / 7.7 kg
slate plate: approx. 18.5 kg / 23 kg
- › **Maximum load capacity:** 100 kg

The frame and the support plate are completely handmade. Slate and wood are natural products with slight variations in the grain. This makes every STOIC unique and distinguishes it from industrially manufactured products.